

Type 26 Catch Basin

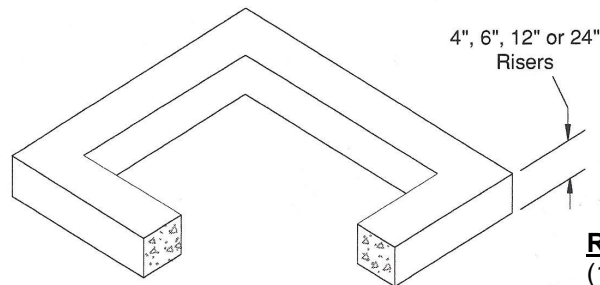

Riser Reinforcement

- (1) #3 Rebar in 2", 4" & 6"
- (2) #3 Rebar in 12"
- (4) #3 Rebar in 24"

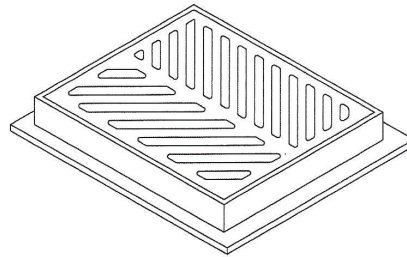
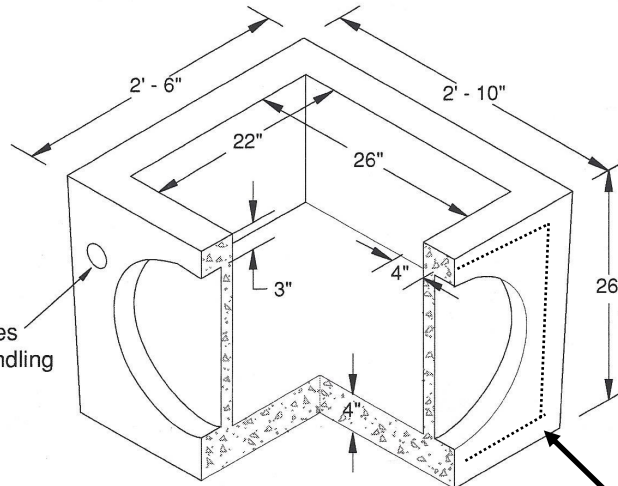

Rebar Placement

#3 Rebar 1" from top,
1" from bottom. #3
Rebar in each corner
1" in from corner.

Top Unit

Frame and grate available.

Risers

2", 4", 6", 12", 24" risers available.

Base Section

Clear opening of knockouts is 18". Knockouts provided on four sides.

Notes

All concrete is 4,000 PSI minimum.
All rebar meets ASTM A615, grade 60.
Weight is 1033 lbs.

- Scale -

All dimensions subject to allowable specification tolerances.